



NEW



JUMBO-BV-VARIO-250-B



JUMBO-BV-VARIO-150-B

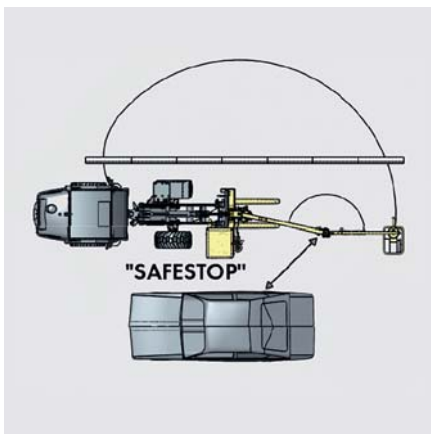

“SAFESTOP” prevents uncontrolled slewing of the articulated boom”

Vacuum Kerb Stone

max. 250 kg/550 lbs

Installation Machine JUMBO-BV-VARIO

The BV-VARIO with articulated boom is equipped with the innovative Probst safety feature “SAFESTOP”. thus highest safety in the slewing range!

Mostly kerb stones are installed one side of the road, while on the other side vehicles are still allowed to drive. Existing knuckle boom jibs provide some advantages, such as space requirements, but usually they have disadvantages because it cannot be avoided that they might swing into the trafficed area. This could cause fatal accidents.

Vacuum Components:

Petrol engine or hydraulic motor and vacuum turbine unit with silencer.

Supply hose and lifting hose HE.

Pickup height from fork prong level up to approximately 1,100 mm (43¼ inch).

Operating Valve unit with handle, dustfilter.

Kerb stone suction gripper with durable foam rubber seal, also suitable for natural kerbstones.

All components can be changed using quick fasteners.

Pillar Swing Crane:

With hydraulic, vertical tilt capability, diagonal to the direction in which it is travelling.

Capable of tilting in the direction in which it is travelling via the pivotal cylinder of the loading bucket.

Swing range of the crane jib appr. 270°.

Total height of appliance in working position approx. 2,910 mm (114,5 inch).

Transport height approx. 2,250 mm (88,5 inch).

The jib can be folded hydraulically.

JUMBO-BV-VARIO-150: incl. kerb stone suction plate WSP-150 (Working load limit 150 kg/330 lbs).

JUMBO-BV-VARIO-200: incl. kerb stone suction plate WSP-200 (Working load limit 200 kg/440 lbs).

JUMBO-BV-VARIO-250: incl. kerb stone suction plate WSP-250 (Working load limit 250 kg/550 lbs).

- With reinforced boom, **250 kg (550 lbs) payload is possible at full extension.** **NEW**
- With universal mounting plate for all common fork carriers of loaders or forklifts, alternatively equipped with hollow tines.
- Innovative Safety Feature: knuckle boom with shifting suspension with „SAFESTOP“. Now it is easy, fast and safe to do installation works also along-side walls, around trees or posts.
- Installing heavy elements by vacuum lifting force light as a feather, combined with best logistic: distribution and installation in one go. Cost effective and health and safety conjus for your workers.
- The jib can be folded down for compact transportation measurements quick and easy via a hydraulic cylinder. Feeding the vacuum to the lifting unit by well thought out design through the knuckle boom link.
- Easy and quick locking of both knuckle boom links by spring loaded bolt.
- Time saving: 7 kerbs, each 1,000 mm (39“) long can be installed without moving the loader.
- Well proven quick change device for fitting different suction plates within less than one minute.
- Installation capacity/day: up to 400 metres.
- Large number of suction plates available for different stone sizes and weights.
- Installation capacity/day: up to 400 metres.
- Large number of suction plates available for different stone sizes and weights.

Type	Type of Drive Petrol Engine kW	Working Width mm (in)	Load Extension mm (in)	Dead Weight kg (lbs)	Hydr. Volumetric Flow l/min (gpm)	Hydr. Backflow Pressure , max. bar (psi)	Hydraulic Connection Pressure bar (psi)	Working Load Limit/WLL -420 mbar kg (lbs)	Order-Number
JUMBO-BV- VARIO-150-B	8.1	7,000 (275.59)	3,500 (137.80)	555 (1,224)				150 (331)	52200016-150
JUMBO-BV- VARIO-200-B	8.1	7,000 (275.59)	3,500 (137.80)	570 (1,257)				200 (441)	52200016-200
JUMBO-BV- VARIO-250-B	8.1	7,000 (275.59)	3,500 (137.80)	575 (1,268)				250 (551)	52200016-250
JUMBO-BV- VARIO-150-H		7,000 (275.59)	3,500 (137.80)	525 (1,157)	16 – 70 (4.23 – 18.49)	10 (145.04)	180 – 320 (2,611 – 4,641)	150 (331)	52200017-150
JUMBO-BV- VARIO-200-H		7,000 (275.59)	3,500 (137.80)	540 (1,190)	16 – 70 (4.23 – 18.49)	10 (145.04)	180 – 320 (2,611 – 4,641)	200 (441)	52200017-200
JUMBO-BV- VARIO-250-H		7,000 (275.59)	3,500 (137.80)	545 (1,202)	16 – 70 (4.23 – 18.49)	10 (145.04)	180 – 320 (2,611 – 4,641)	250 (551)	52200017-250

*) Details in the general sales conditions at the end of the catalogue or at www.probst-handling.com/en/gtc.

011223 Technical data contained in this catalogue can be modified without prior notice in the interest of progress. Illustrations are exemplary and non-binding. No liability accepted for any misprints, mistakes and errors.